



ATSC 8VSB Modulator IP Core
Specification

Release Information

Name	ATSC 8VSB Modulator IP Core
Version	2.0
Build date	2022.06
Ordering code	ip-atsc-8vsb-modulator
Specification revision	r1884

Features

The IP core is full-featured 4-channel digital ATSC 8VSB modulator and is fully compatible with this standard:

- ATSC A/53 Part 2

License

License:

- Netlist for One FPGA Family or Full Source Code (Verilog, SDC/XDC)
- Perpetual
- Without Quantitative Restrictions
- Worldwide
- Royalty-free
- Free Remote Technical Support for 1 Year

Deliverables

The ATSC 8VSB Modulator IP Core includes:

- EDIF/NGC/QXP/VQM netlist for Xilinx Vivado/ISE, Intel (Altera) Quartus, Lattice Diamond or Microsemi (Actel) Libero SoC
- IP Core testbench scripts
- Design examples for Xilinx, Intel (Altera), Lattice, and Microsemi (Actel) evaluation boards

IP Core Structure

Figure 1 shows the ATSC 8VSB Modulator IP Core block diagram.

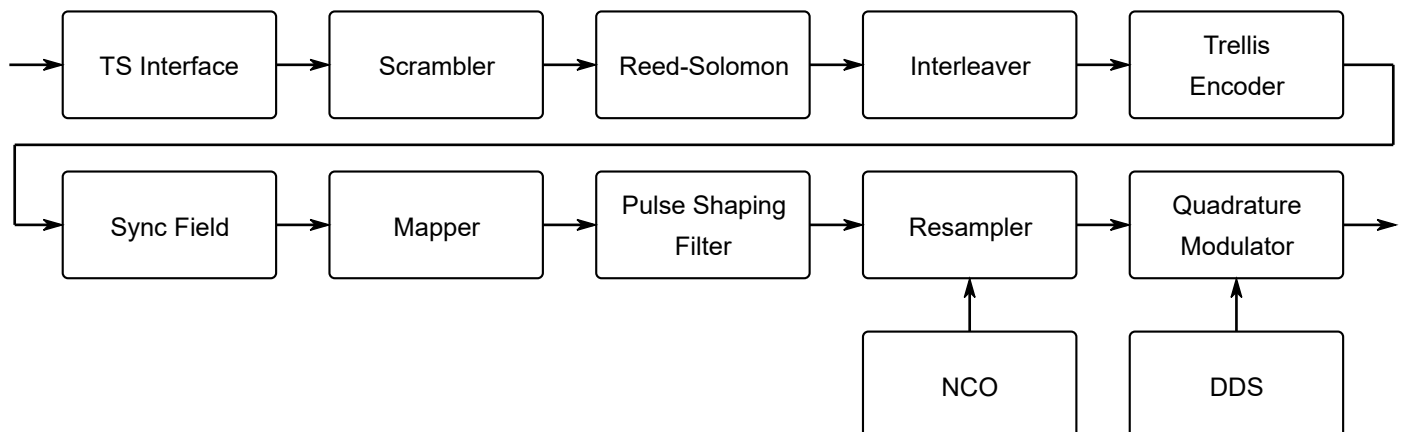

Figure 1. The ATSC 8VSB Modulator IP Core block diagram

Port Map

Figure 2 shows a graphic symbol, and Table 1 describes the ports of the ATSC 8VSB Modulator IP Core.

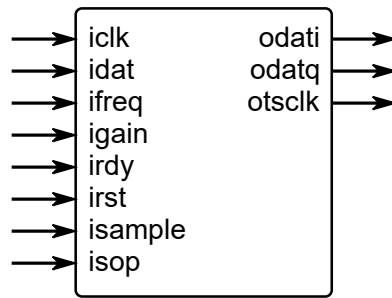

Figure 2. The ATSC 8VSB Modulator port map

Table 1. The ATSC 8VSB Modulator port map description		
Port	Width	Description
iclk	1	The main system clock. The IP Core operates on the rising edge of iclk.
idat	8	input (information) data
ifreq	32	output intermediate frequency
igain	W_DAC	output gain control
irdy	1	Modulator output data request.
irst	1	The IP Core synchronously reset when irst is asserted high.
isample	32	bandwidth control (symbol rate): 0.01% to 25% of iclk
isop	1	input sync-word byte marker (0x47 TS)
odati	W_DAC	modulator output at baseband (I channel) or at an intermediate frequency
odatq	W_DAC	modulator output at baseband (Q channel)
otsclk	1	ready to accept input data

IP Core Parameters

Table 2 describes the ATSC 8VSB Modulator IP Core parameters, which must be set before synthesis.

Table 2. The ATSC 8VSB Modulator IP Core parameters description

Setting Port Parameters

Some input ports that control the IP Core operation need to be set to suit custom configuration.

Carrier frequency:

$$ifreq = \frac{\text{Output Frequency (Hz)}}{\text{iclk rate (Hz)}} \cdot 2^{32}$$

Symbol rate:

$$isample = \frac{\text{Output Symbol rate (Hz)}}{\text{iclk rate (Hz)}} \cdot 2^{34}$$

Output gain:

$$igain = 8192 \cdot \left(10^{\frac{\text{Output gain (db)}}{20}} - 1 \right)$$

Performance and Resource Utilization

The values were obtained by automated characterization, using standard tool flow options and the floorplanning script delivered with the IP Core. The IP Core fully supports all Xilinx and Altera FPGA families, including Spartan, Zynq, Artix, Kintex, Virtex, Cyclone, Arria, MAX, Stratix. Table 3 summarizes the ATSC 8VSB Modulator IP Core measurement results.

Table 3. The ATSC 8VSB Modulator performance				
IP Core parameters	FPGA type			
	Resource	Speed grade, maximal system frequency		
W_DAC=16	Altera Cyclone 10 LP 10CL080			
	6289 LEs (7%) 14 M9K RAM blocks (4%) 12 DSP (18x18) (8%)	-8, Fmax	-7, Fmax	-6, Fmax
		120.0 MHz	140.0 MHz	160.0 MHz
W_DAC=16	Xilinx Virtex-7 XC7VX330T			
	1595 Slices (4%) 12 18K RAM blocks (2%) 12 DSP (18x18) (1%)	-1, Fmax	-2, Fmax	-3, Fmax
		220.0 MHz	260.0 MHz	300.0 MHz

IP Core Interface Description

IP core has two ways of forming the output spectrum:

- Baseband (using **odati** and **odatq**), **ifreq** equal 0
- Intermediate frequency (using **odati**), **ifreq** not equal 0

Digital-to-analog converters must operate synchronously with the ATSC 8VSB Modulator IP core. Figure 3 shows the DAC connection diagram for baseband mode and Figure 4 shows the timing diagram for this mode.

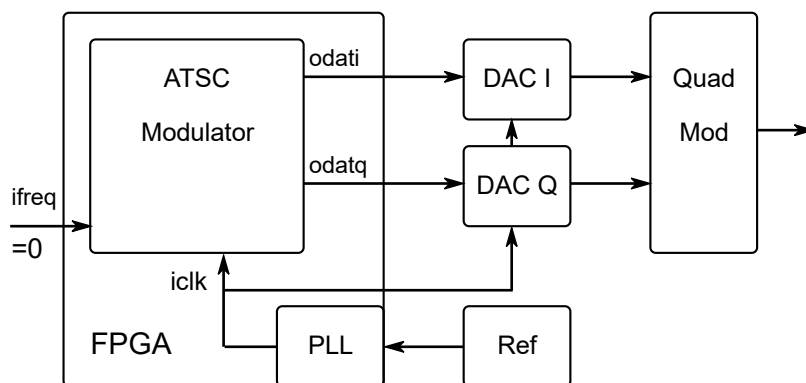

Figure 3. The DAC connection diagram for baseband mode.

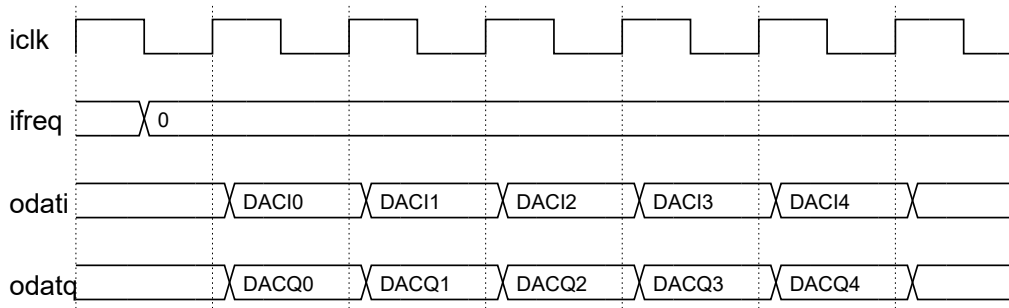

Figure 4. The timing diagram for baseband mode.

Figure 5 shows the DAC connection diagram for IF mode and Figure 6 shows the timing diagram for this mode. The output intermediate frequency port **ifreq** sets the central frequency for **odati** modulator output port.

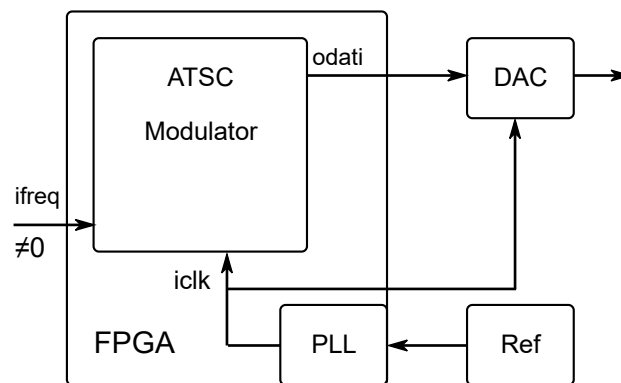

Figure 5. The DAC connection diagram for IF mode.

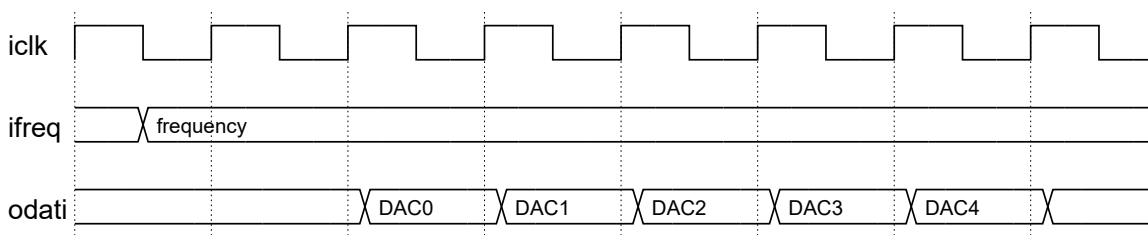

Figure 6. The timing diagram for IF mode.

Figure 7 shows an example of the waveform of the input interface. Handshake port **otsclk** controls input dataflow. Input data is read from the input **idat** only when **otsclk** is equal to logical one ("1").

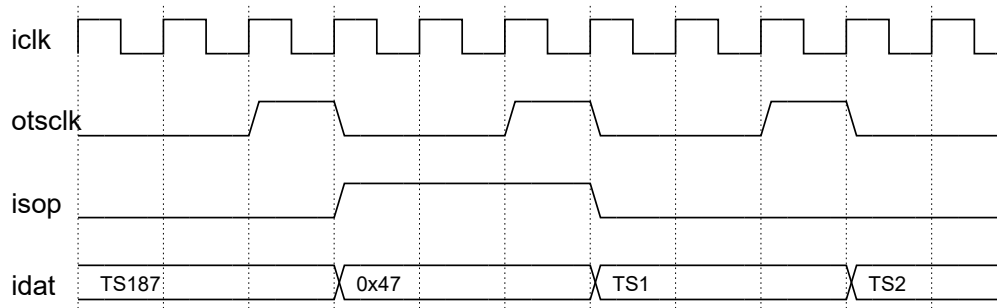

Figure 7. The timing diagram of the IP Core input interface.

The ATSC 8VSB Modulator IP Core supports 4-channel operating mode with the AD9789 RF DAC and allows to output spectrum 0 MHz to 1100 MHz.

Upgrade and Technical Support

Free remote technical support is provided for 1 year and includes consultation via phone, E-mail and Skype. The maximum time for processing a request for technical support is 1 business day.

For up-to-date information on the IP Core visit this web page

<https://www.modemica.com/>

Feedback

Modemica OU

Sepapaja 6, Tallinn, 15551, Estonia

Tel.: +39-350-0080495

E-mail: info@modemica.com

Skype: fpgahelp

website: <https://www.modemica.com>

Revision history

Version	Date	Changes
2.0	2022.06.22	4-channel ATSC modulator for AD9789 DAC
1.0	2018.07.10	Official release